



RIGOL

BatHolder138

Battery Holder

User Guide

Jun. 2024

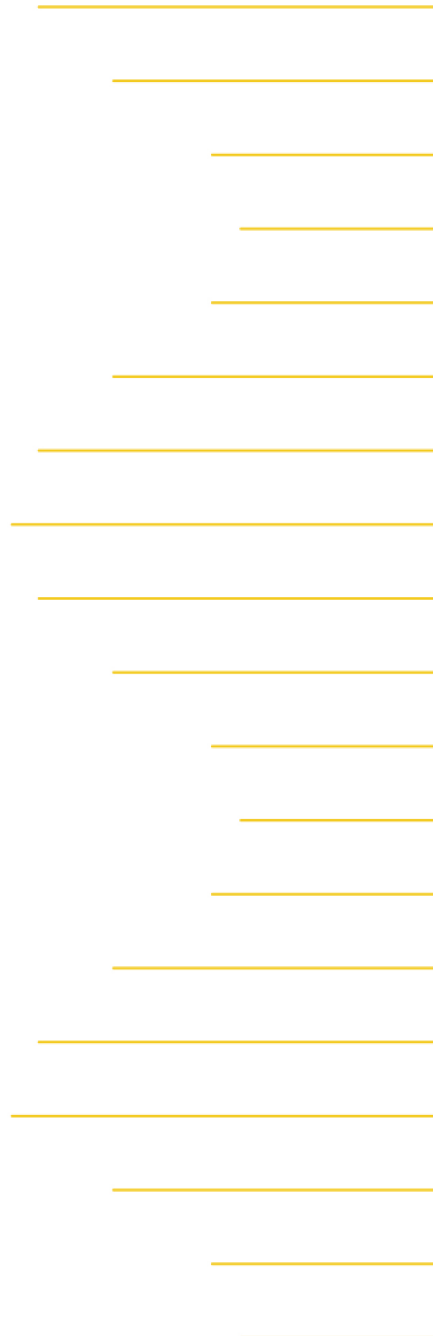

Guaranty and Declaration

Copyright

© 2024 RIGOL TECHNOLOGIES CO., LTD. All Rights Reserved.

Trademark Information

RIGOL® is the trademark of RIGOL TECHNOLOGIES CO., LTD.

Notices

- RIGOL products are covered by P.R.C. and foreign patents, issued and pending.
- RIGOL reserves the right to modify or change parts of or all the specifications and pricing policies at the company's sole decision.
- Information in this publication replaces all previously released materials.
- Information in this publication is subject to change without notice.
- RIGOL shall not be liable for either incidental or consequential losses in connection with the furnishing, use, or performance of this manual, as well as any information contained.
- Any part of this document is forbidden to be copied, photocopied, or rearranged without prior written approval of RIGOL.

Product Certification

RIGOL guarantees that this product conforms to the national and industrial standards in China as well as the ISO9001:2015 standard and the ISO14001:2015 standard. Other international standard conformance certifications are in progress.

Contact Us

If you have any problem or requirement when using our products or this manual, please contact RIGOL.

E-mail: service@rigol.com

Website: <http://www.rigol.com>

Section	Description	Page
	List of Figures.....	II
	List of Tables.....	III
1	Safety Requirement	1
1.1	General Safety Summary	1
1.2	Safety Notices and Symbols	1
1.3	Battery Holder Using Requirements	2
1.4	Battery Installation Requirements	2
1.5	Battery Holder Storage Requirements	3
1.6	Battery Holder Disposal Requirements	4
1.7	Environmental Considerations	4
2	Product Features	5
3	Document Overview	6
4	General Inspection	7
5	Battery Holder Overview	8
6	To Use the Battery Holder	10
6.1	To Install Batteries	10
6.2	To Install Battery Holder	11
6.3	To Remove Battery Holder	13
6.4	Activation	14
6.5	Self-calibration	16
6.6	To Charge Battery Holder	17
6.7	Battery Capacity Indicator	18
6.8	To Manage Battery Holder	19
7	Troubleshooting	21
8	Specifications	23
9	Battery Shipping Label	25
10	Appendix	26
10.1	Appendix A: Accessories	26
10.2	Appendix B: Warranty	26

List of Figures

Figure 5.1 Battery Holder Front/Rear View	8
Figure 6.1 Battery Installation Sequence	11
Figure 6.2 Activator	15
Figure 6.3 Connect the Activator	16

List of Tables

Table 6.1 Recommended Battery Model	11
Table 6.2 LED Indicator - Charging	18
Table 6.3 LED Indicator - Standby and Discharging	19
Table 8.1 Specifications	23
Table 8.2 Battery Performance	23
Table 8.3 Environmental Specifications	24
Table 8.4 Mechanical Characteristics (Battery Holder)	24

1 Safety Requirement

1.1 General Safety Summary

Please review the following safety precautions carefully before putting the product into operation so as to avoid any personal injury or damage to the product and any product connected to it. To prevent potential hazards, please follow the instructions specified in this manual to use the product properly.

When using this product, you may need to use other devices. For warnings and precautions of using those devices, refer to the "Safety Requirement" provided in their manuals.

1.2 Safety Notices and Symbols

Safety Notices in this Manual:



WARNING

Indicates a potentially hazardous situation or practice which, if not avoided, will result in serious injury or death.



CAUTION

Indicates a potentially hazardous situation or practice which, if not avoided, could result in damage to the product or loss of important data.

Safety Notices on the Product:

- **DANGER**
It calls attention to an operation, if not correctly performed, could result in injury or hazard immediately.
- **WARNING**
It calls attention to an operation, if not correctly performed, could result in potential injury or hazard.
- **CAUTION**
It calls attention to an operation, if not correctly performed, could result in damage to the product or other devices connected to the product.

Safety Symbols on the Product:



Hazardous Voltage **Safety Warning** **Protective Earth Terminal** **Chassis Ground** **Test Ground**

1.3 Battery Holder Using Requirements

- Do not use the battery holder in an environment of water and corrosive gases.
- Do not use the battery holder in environments that are outside the specified range.
- The battery holder does not support hot swapping. Before installing or removing the battery holder, power off the instrument and disconnect all charge/discharge cables to avoid damaging the instrument or battery holder.

1.4 Battery Installation Requirements

- Although the battery holder has the reverse polarity protection, install the batteries correctly according to the designation of polarity (+ and - symbol) on the battery holder cover, as is shown in the figure below. Reverse polarity can cause self-calibration error and even damage the battery holder in the long term.

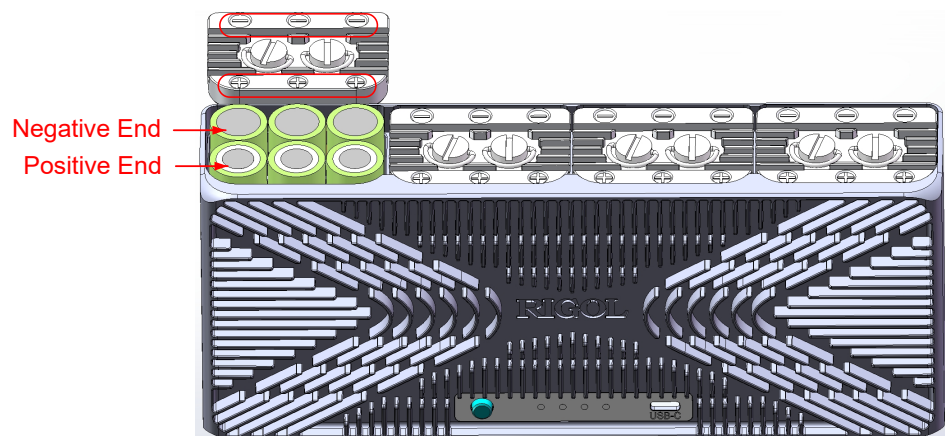

- Do not install any batteries other than the 18650 flat-top Lithium-ion batteries, even if they are of the same size.
- Only use 18650 flat-top Lithium-ion batteries. Do not insert 16650 or 12700 batteries into the battery holder using the conversion device.
- Never use button-top batteries. Only 18650 flat-top Lithium-ion batteries with 65 mm length can be installed in the battery holder. As the button-top batteries are taller than 65 mm, you may damage the battery holder if you force the button-top batteries in.

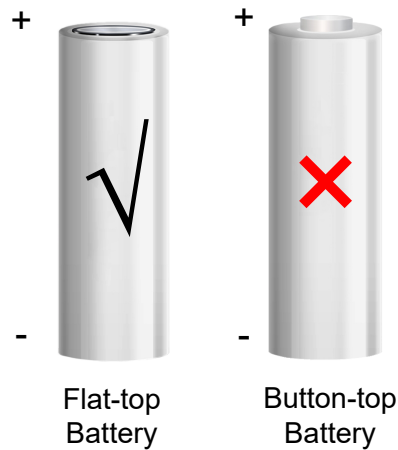

- Tighten the cover after inserting Lithium-ion batteries in the battery holder.
- Use new Lithium-ion secondary batteries (hereinafter referred to as Li-ion batteries) of the same brand, model, and state^[1] with 3.0 V to 4.2 V initial voltage and 3000 mAh to 3500 mAh nominal capacity per unit. For the battery specifications, refer to [Table 8.2 Battery Performance](#).
- Use batteries with security guarantee. Otherwise, fire or explosion may occur to bring immeasurable losses. RIGOL shall not be liable for those losses.
- Before and after installation, inspect the battery holder carefully to ensure no foreign objects (e.g. water, sheet metal, flammable label) inside the battery holder.

NOTE

[1]: The same state means that the voltage variations of all battery cells should lie between ± 50 mV (3.6 V to 4.0 V) and ± 100 mV (3.0 V to 3.6 V/4.0 to 4.2 V).

1.5 Battery Holder Storage Requirements

- Store the battery holder at temperatures between -10°C and 50°C with less than 80% relative humidity without condensation.
- Store the battery holder in an environment free of corrosive gases.
- Do not modify the battery holder.
- Do not hit the battery holder or drop it onto the hard floor. Otherwise, its casing will be distorted, causing damage to internal structure of the battery holder. It may make it difficult to remove batteries or even damage the internal circuit to bring fire or explosion.
- Keep the battery holder away from exposed metal objects or particles because they may cause a short-circuit or damage the battery holder.
- When the battery holder is stored with batteries installed, it is recommended to perform a discharge-charge cycle or charge the battery every 3 months. You can

also press the button to check the battery capacity regularly. Otherwise, the self-discharge of the battery holder would make the battery run out of charge and reset the battery holder or even cause irreversible damage to the battery.

- If you do not use the battery holder for an extended period, it is recommended to remove the batteries.
- The batteries inside the battery holder have a shelf life. Preserve, maintain, and replace the batteries properly according to the battery manual.
- When shipping the battery holder, please use a Li-ion battery label. For details, please refer to *Battery Shipping Label*.

1.6 Battery Holder Disposal Requirements

- When the battery holder is ready for disposal, remove all battery cells before disposing of the battery holder. As lithium-ion batteries are classified as hazardous waste, please properly dispose of them according to local government regulations.
- When all batteries are removed, be free to dispose of the battery holder.
- Never dispose of the battery holder in fire or its internal electrical components may emit toxic fumes. It can even cause explosion or serious personal injury if the battery holder still contains batteries.

1.7 Environmental Considerations

The following symbol indicates that this product complies with the WEEE Directive 2012/19/EU.



The equipment may contain substances that could be harmful to the environment or human health. To avoid the release of such substances into the environment and avoid harm to human health, we recommend you to recycle this product appropriately to ensure that most materials are reused or recycled properly. Please contact your local authorities for disposal or recycling information.

You can click on the following link <https://int.rigol.com/services/services/declaration> to download the latest version of the RoHS&WEEE certification file.

2 Product Features

RIGOL provides detachable battery holders for some of its product models. After the battery holder is installed, it powers the instrument as a power supply when the instrument has not been connected to AC power. It enables the instrument to work for hours in place where an AC power source is not available (e.g. in the field). The actual operating time varies depending on the instrument model. A battery holder option makes it more flexible to use the instrument, giving you unlimited test freedom from power source.

The battery holder has the following features:

- Support a maximum of 24 standard 18650 battery cells.
- Two charging methods: external charge and the instrument's charge system.
- It has the cell balancing method and battery protection methods, protecting batteries from over voltage, under voltage, over current, short circuit, high temperature, and low temperature.

3 Document Overview

This manual gives you a quick overview of the functions, using methods, and safety precautions of RIGOL BatHolder138.



TIP

For the latest version of this manual, download it from RIGOL official website (<http://www.rigol.com>).

Publication Number

UGN01101-1110

Format Conventions in this Manual

1. Key

The front panel key is denoted by the menu key icon. For example, indicates the "Default" key.



2. Menu

The menu item is denoted by the format of "Menu Name (Bold) + Character Shading" in the manual. For example, **Setup** indicates the "Setup" sub-menu under the "Utility" function menu. You can click or tap **Setup** to access the "Setup" menu.

3. Operation Procedures

The next step of the operation is denoted by ">" in the manual. For example,



> **Utility** indicates first clicking or tapping  and then clicking or tapping **Utility**.

4 General Inspection

1. Inspect the packaging

If the packaging has been damaged, do not dispose the damaged packaging or cushioning materials until the shipment has been checked for completeness and has passed both electrical and mechanical tests.

The consigner or carrier shall be liable for the damage to the instrument resulting from shipment. RIGOL would not be responsible for free maintenance/rework or replacement of the instrument.

2. Inspect the instrument

In case of any mechanical damage, missing parts, or failure in passing the electrical and mechanical tests, contact your RIGOL sales representative.

3. Check the accessories

Please check the accessories according to the packing lists. If the accessories are damaged or incomplete, please contact your RIGOL sales representative.

5 Battery Holder Overview

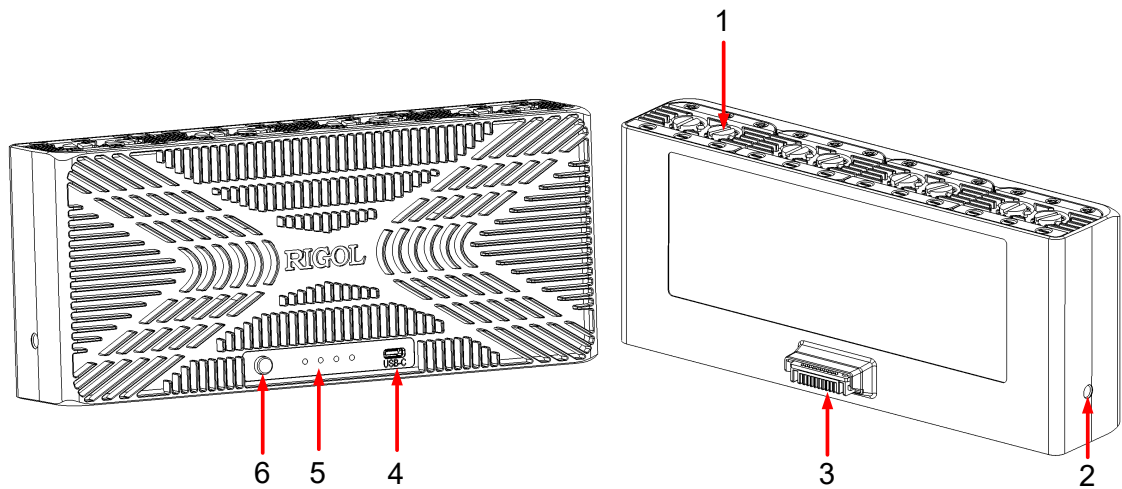

Figure 5.1 Battery Holder Front/Rear View

1. Battery Holder Cover

Open the cover to replace batteries.

2. Screw Hole

Install the screw of the mounting frame into the screw hole to secure the battery holder to the mounting frame.

3. Connector

- Connect the activator to activate the battery holder or charge the battery holder.
- Connect the connector to the rear-panel battery holder interface of the instrument. After that, you can use the instrument (connected to AC power) to power the battery holder or use the battery holder to power the instrument (not connected to AC power).

4. Type-C Interface

Connect the interface to an external powered device (supporting the PD 3.0 protocol).

5. LED Indicator

Indicates the battery holder capacity and operating status. For details, refer to [Battery Capacity Indicator](#).

6. Button

- When the battery holder is not connected to the instrument with no power source applied for over 120 s, it enters sleep mode. In the sleep mode, "short

press^[1] the button to activate the LED indicators and enable 11.66 V bus output.

- Long press ^[2] the button to power on/off the battery holder. You can long press the button for more than 2 s and release the button after the boot/shutdown animation is complete. During the boot/shutdown animation, if you release the button, the process stops (four LED indicators blinking concurrently) and restores to the original state.

NOTE

[1]: "Short press" refers to a gesture of pressing and releasing the button within a period of 50 ms to 700 ms.

[2]: "Long press" refers to a gesture of pressing and holding the button for over 2 seconds and then releasing the button.

6 To Use the Battery Holder

This chapter introduces the basic operations of the battery holder, including installing batteries, installing the battery holder, activation, self-calibration, charging, managing the battery holder, and check the battery power.

Follow the steps below if you use the battery holder for the first time:

1. After you have purchased the batteries that meet the requirements, install the batteries in the battery holder (refer to *To Install Batteries*).
2. Install the battery holder onto your instrument (refer to *To Install Battery Holder*).
3. Apply AC power to the instrument and perform the activation and self-calibration process (refer to *Activation* and *Self-calibration*).
4. After the self-calibration passes, you can use the battery holder.

6.1 To Install Batteries

The battery holder allows you to insert the batteries as required. Please follow the requirements specified in *Battery Installation Requirements* to install the batteries so as to avoid any personal injury or damage to the product and any product connected to it. The company would not be responsible for any problems arising from operation in violation of precautions.

TIP

The battery holder is not equipped with batteries when leaving factory. Please install the batteries when first use the battery holder.

To replace or install batteries, follow the steps below:

1. Disconnect the battery holder from the instrument or charger. Loosen the screws on the cover of the battery holder and remove the cover.

Unscrewing the battery cover resets the self-calibration status of the battery holder. To use the battery holder, install new specified Li-ion batteries and perform the activation and self-calibration again (refer to *Activation* and *Self-calibration*).

2. Remove all batteries (if any) from the battery holder.

3. Install batteries from position 1 following the sequence as illustrated in the figure below. Group 6 battery cells as a pack (No.1-6 as pack 1, 7-12 as pack 2, 13-18 as pack 3, 19-24 as pack 4). The batteries must be installed in packs (at least two packs).

- If you do not fill the battery holder with 4 battery packs (e.g. only 2 or 3 packs), it will cause insufficient capacity of the battery holder and decreased operating time of the instrument.

- If only one pack (6 battery cells) is installed, the battery holder is not available for use.
- The installed batteries must meet the requirements specified in [Table 8.2 Battery Performance](#). It is recommended to use the Li-ion battery model mentioned in [Table 6.1 Recommended Battery Model](#) for better user experience.

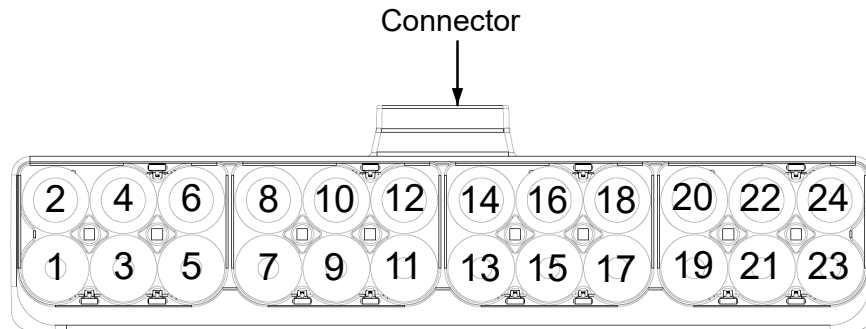

Figure 6.1 Battery Installation Sequence

4. Close the battery cover and tighten the screws.
5. Perform the activation and self-calibration by referring to [Activation](#) and [Self-calibration](#).
6. After completing the activation and self-calibration, you can use the battery holder.

Table 6.1 Recommended Battery Model

Battery Model	Manufacturer
N18650CR	Zhengzhou BAK Battery Co., Ltd
CMINR18650F9E	Dongguan CHAM Battery Technology Co., Ltd

6.2 To Install Battery Holder

This section illustrates how to install the battery holder onto your instrument by taking DHO4000 series oscilloscope as an example.



CAUTION

The battery holder does not support hot swapping. Before installing and removing the battery holder, power off the instrument and disconnect all power cables to avoid damaging the instrument or battery holder.

To install the battery holder, follow the steps below:

1. See the figure below. Fit the battery holder into the frame, aligning the frame screws with the screw holes on the battery holder.

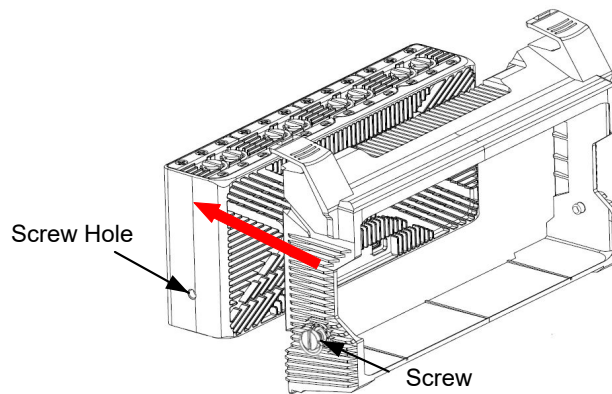
**CAUTION**

Hold them carefully to avoid pinching your hands or dropping them onto the ground.

2. Tighten the screws on the frame to the right to secure the battery holder to the frame.

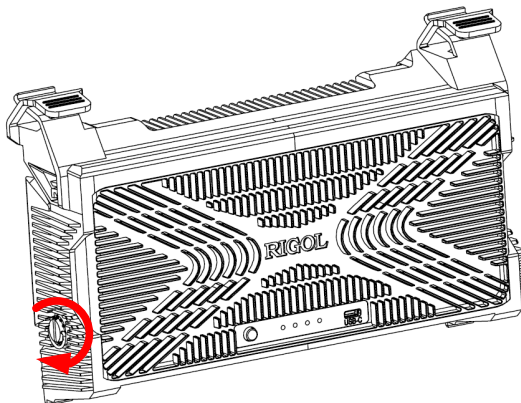

3. Turn off the instrument and disconnect it from the power source. Flip the slider of the rear-panel battery holder interface connector to the right to open the connector.

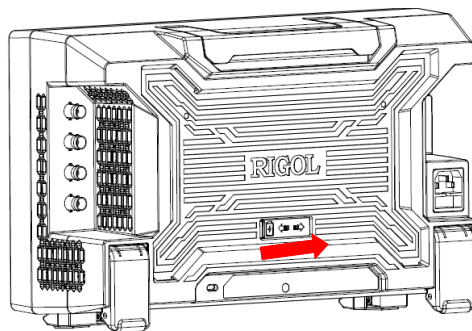

4. Orient the battery holder on the instrument's rear panel and insert the two feet of the battery holder into the instrument slots at the same time.

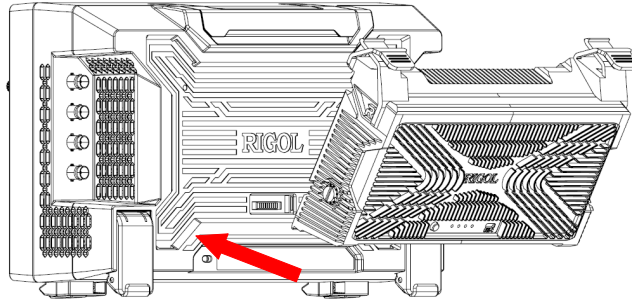

5. Push the battery holder up toward the instrument to align the connector on the battery holder with the rear-panel interface on your instrument.

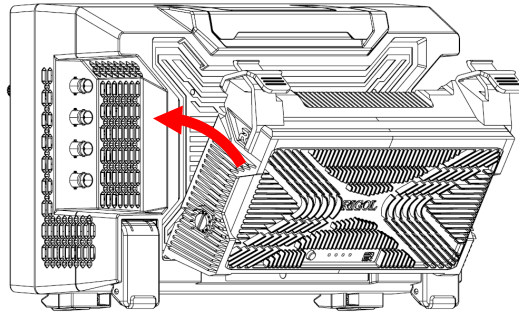

6. Press the two buckles on the frame and snap them into the instrument grooves at the same time.

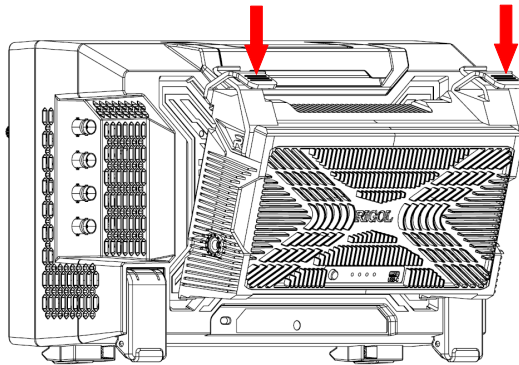

6.3 To Remove Battery Holder

This section illustrates how to remove the battery holder from your instrument by taking DHO4000 series oscilloscope as an example.

CAUTION



The battery holder does not support hot swapping. Before installing and removing the battery holder, power off the instrument and disconnect all power cables to avoid damaging the instrument or battery holder.

To remove the battery holder, follow the steps below:

1. Turn off the instrument and disconnect it from the power source.
2. As shown in the figure below, hold the battery holder steady with both hands from behind the instrument and then press the buckles of the battery holder to remove the battery holder.

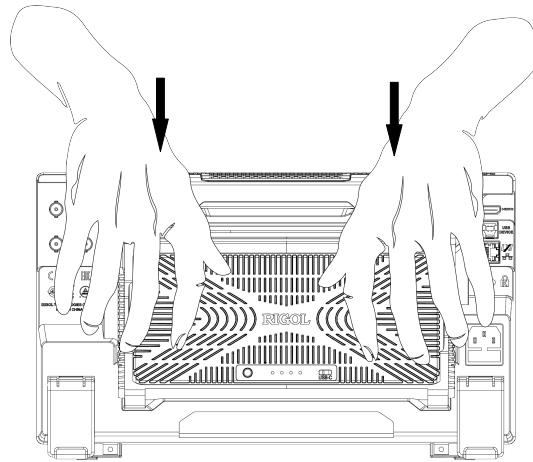

CAUTION

Place the instrument on a flat and large bench to avoid pinching your hands or dropping it onto the ground, and remove the battery holder referring to the gesture as shown in the figure above.

3. Flip the slider of the rear-panel battery holder interface connector to the left to close the connector.

6.4 Activation

When batteries are replaced, the internal main power supply circuit of the battery holder is cut off for which you cannot use the battery holder directly. You need to install the battery holder onto the instrument and apply AC power to activate the battery holder. You can also use the battery holder activator to activate the battery holder.

Activate the Battery Holder Using Activator

The battery holder activator allows you to activate the battery holder to power the instrument when AC power source is not available. The battery holder activator is as shown in the figure below.

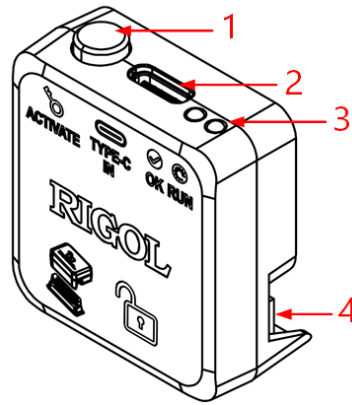

Figure 6.2 Activator

1. Activator button.
2. Type-C interface, used to connect power.
3. Activator indicator.
4. Activator connector, used to connect the battery holder.

To use the activator to activate the battery holder, follow the steps below.

1. Connect the activator to the battery holder connector correctly, as shown in the figure below.
2. Use the USB Type-C cable to connect an adaptor (5 V/3 A, 9 V/3 A, 12 V/3 A) supporting PD 3.0 and then apply the AC power source. You can also connect a mobile power source (5 V/3 A, 9 V/3 A, 12 V/3 A). The indicator of the activator lights (in red).
3. Press the activator button to activate the battery holder. When the activator indicator turns into green, the activation is successful.

NOTE

After the battery holder is activated by the activator, it only powers the instrument. If you want to use the charge-discharge function, connect the battery holder to the instrument and apply the AC power to complete the self-calibration process (refer to *Self-calibration*).



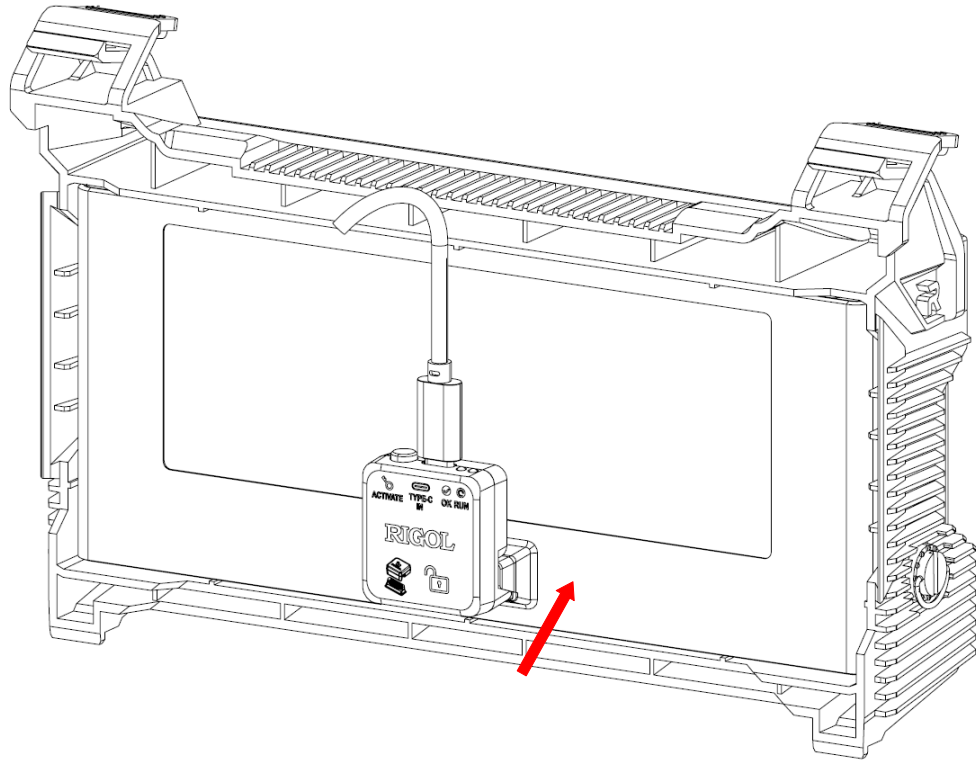

Figure 6.3 Connect the Activator

Activate the Battery Holder Using the Instrument

Install the battery holder onto the instrument correctly by referring to [To Install Battery Holder](#). Apply AC power to the instrument to activate the battery holder.

After the battery holder is activated inside the instrument, the self-calibration automatically starts (refer to [Self-calibration](#)).

6.5 Self-calibration

After the battery holder is activated, you can calibrate it inside the instrument after installing the battery holder on the instrument and applying AC power. After the calibration is complete, you can use the battery holder. The basic idea of self-calibration is to complete a charge-discharge cycle and check the status of the battery during the process. An uncalibrated battery holder can only power the instrument not applied to AC power. The other functions are not available.

To calibrate the battery holder, follow the steps below:

1. Install the battery holder onto the instrument correctly by referring to [To Install Battery Holder](#).
2. Apply AC power to the instrument.

NOTE

If the battery holder has not been activated, first activate the battery holder and then the self-calibration starts. If the battery holder has been activated but not passed the self-calibration, then the self-calibration starts.

3. The battery holder starts to be charged and calibrated. After the battery holder is fully charged, the discharge process automatically starts (the instrument is always on during the process).
4. Operate the instrument until the battery power is below 40% (the voltage down to approximately 3.6 V). The self-calibration is complete. After the self-calibration is done, a prompt window will pop up.



TIP

- The calibration process can take hours to complete. It is recommended to perform self-calibration when the instrument is idle. It may take about 6 to 8 hours depending on the battery model and capacity. You can view the specific calibration time in *Battery Holder Information*.
- When the activated battery holder is installed to the instrument with AC power applied for the first time, the self-calibration automatically starts. When the battery holder is performing self-calibration, the battery label is displayed as  (in gray).

6.6 To Charge Battery Holder

You can charge the battery holder in the instrument (AC power applied) or in an external battery charger.



CAUTION

Do not attempt to charge the battery holder at temperatures below 0°C (+32°F) or above +40°C (+104°F). Otherwise, the battery will not be fully charged or even damaged.

Internal Charge

The battery-powered instrument has a built-in charge system. After the instrument has a battery holder installed, it can charge the battery holder inside while the AC power is applied.

To charge the battery holder inside the instrument, follow the steps below:

1. Install the battery holder onto the instrument (refer to *To Install Battery Holder*).
2. Apply external power from the instrument AC adapter. The LED indicators on the battery holder blink and the battery holder starts to charge.

While the instrument is powered on, you can check the capacity of the battery holder from the instrument's display screen. While the instrument is powered off, you can check the capacity through the LEDs on the battery holder (refer to *Table 6.2 LED Indicator - Charging*).

External Charge

You can use the activator to charge the battery holder. To use the activator to charge the battery holder, follow the steps below.

1. Connect the activator to the battery holder connector correctly as shown in [Figure 6.3](#).
2. Use the USB Type-C cable to connect an adaptor (12 V/3 A) that conforms to the Power Delivery (PD) 3.0 Specification and then apply the AC power source. You can also connect a mobile power source (12 V/3 A).
3. The LED indicators blink and the battery holder starts to charge immediately.

While the battery holder is charging, you can check its capacity through the LEDs on the battery holder (refer to [Table 6.2 LED Indicator - Charging](#)).

TIP

- When the battery holder is connected to the instrument (AC power applied) and an external charger at the same time, if the instrument is powered on, only the external charger will charge the battery holder; if the instrument is powered off, only the instrument's internal charge system will charge the battery holder.
- When the battery holder is connected to the instrument (no AC power applied) and an external charger at the same time, the battery holder can power the instrument while being charged by the external charger.



6.7 Battery Capacity Indicator

When the battery holder is charging or discharging, the 4 LED indicators will indicate its charge/discharge status.

Table 6.2 LED Indicator - Charging

Battery Holder Capacity	LED Indicator				Description
	1	2	3	4	
1% to 25%	Blinking	-	-	-	-
26% to 50%	Lit	Blinking	-	-	-
51% to 75%	Lit	Lit	Blinking	-	-
76% to 99%	Lit	Lit	Lit	Blinking	-
100%	Lit	Lit	Lit	Lit	-
Error	Blinking	Blinking	Blinking	Blinking	Connected to charger that fails to meet the specification

When the battery holder is in standby mode, you can "short press" the button to activate the battery capacity display.

Table 6.3 LED Indicator - Standby and Discharging

Battery Holder Capacity	LED Indicator			
	1	2	3	4
1% to 25%	Lit	-	-	-
26% to 50%	Lit	Lit	-	-
51% to 75%	Lit	Lit	Lit	-
76% to 100%	Lit	Lit	Lit	Lit

6.8 To Manage Battery Holder

After the battery holder is installed onto the instrument properly, you can use the instrument to check the battery holder information and configure the battery holder. This chapter introduces how to manage the battery holder via your instrument (taking DHO4000 series oscilloscope as an example).

Click or tap  > **Utility** > **PMU** to enter the power management menu.

Long Battery Life Mode

After the long battery life mode is enabled, the instrument enters the low power mode which can preserve battery life.

When battery power is detected, a prompt window "Enter long battery life mode?" is displayed. Click or tap **OK** to enter long battery life mode or **Cancel** to enter normal mode.

You can also click or tap the **Long battery life mode** on/off switch to enable or disable the long battery life mode. This function is available only when battery power is detected. Otherwise, it is grayed out.

Self-calibration

The self-calibration is automatically enabled after the battery holder is activated. Besides, you can perform the self-calibration manually.

Apply AC power to the instrument. Then click or tap **Battery self check** and a prompt window is displayed. Click or tap **OK** to perform the self-calibration. For details, refer to [Self-calibration](#).

Battery Power

This item displays remaining battery power.

You can also check the battery's remaining power and status via the battery icon at the lower-right of the screen.

- The number in the battery icon  indicates the remaining power.
- When the battery power falls below 20%, the battery icon turns into red.

- When the instrument is connected to AC power to charge the battery holder, the battery charging icon appears.
- When the battery holder is performing self-calibration, the battery icon is displayed as  (in gray).

Remaining Time

This item displays the remaining operating time of the battery holder.

Battery Holder Information

Click or tap **Battery holder information** and the information menu is displayed as shown in the figure below. You can check whether the battery cell is installed to a specified position, the battery voltage, charging/discharging current, and the battery status. When the battery holder is in self-calibration or an error occurs, the prompt message (e.g. "Attention: Battery holder locked. Abnormal battery temperature.") will pop up in this menu. For troubleshooting battery issues, refer to [Troubleshooting](#).

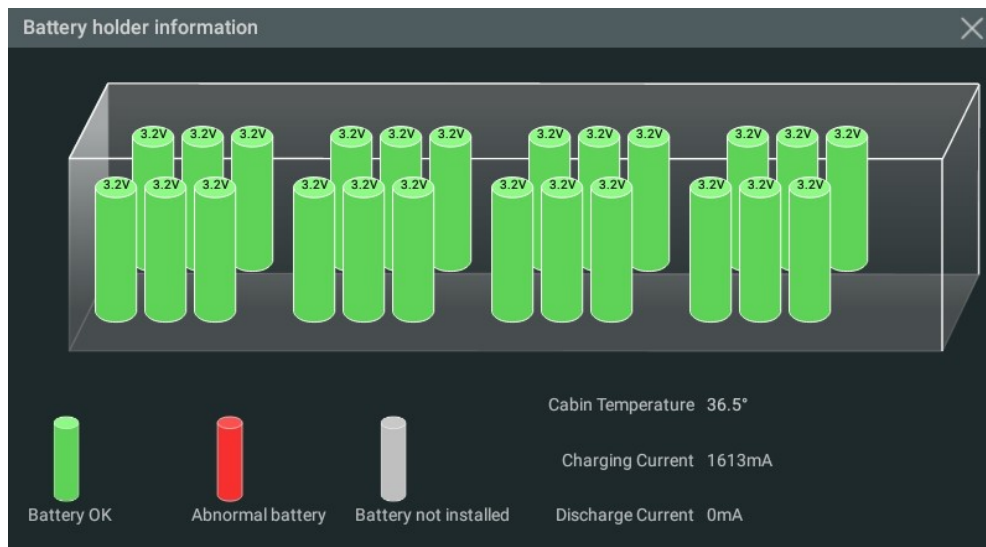

7 Troubleshooting

The battery holder locks when issues occur. You need to troubleshoot the battery issues and execute the self-calibration again. The battery holder is available for use only when it passes the self-calibration. The issue types will be displayed in *Battery Holder Information* interface. The possible issues (including self-calibration failure) and suggested solutions are as follows.

1. Abnormal battery temperature.

Stop using the battery holder. Ensure that it is within the proper ambient temperature range (0 to 40°C).

2. Battery cells in the same pack vary a lot in voltage.

Stop using the battery holder. Remove the battery cells with too great voltage variance according to the prompt message. Install new cells whose voltage variance and capacity variance meet the requirements as shown in the table below.

Initial voltage variance	±50 mV (3.6 V to 4.0V)
	±100 mV (3.0 V to 3.6 V/4.0 V to 4.2 V)
Battery capacity variance	<5% x nominal capacity

3. Battery cells in different packs vary a lot in voltage.

Stop using the battery holder. Remove the battery cells with too great voltage variance according to the prompt message. Install new cells whose voltage variance and capacity variance meet the requirements (refer to the table above).

4. Abnormal battery voltage.

Stop using the battery holder. Remove the battery cells with abnormal voltage. Install new cells and ensure that the initial voltage variance can meet the requirements (3.0 V to 4.2 V).

5. Abnormal charging/discharging current and others.

Stop using it immediately and contact RIGOL.

6. Self-calibration fails.

- a. Check whether at least two complete battery packs are installed.
- b. Check whether the requirements specified in *Battery Installation Requirements* is met.
- c. Check whether the batteries meet the requirements specified in *Table 8.2 Battery Performance*.
- d. Execute self-calibration again.

e. If the problem still persists, please contact RIGOL.

8 Specifications

Table 8.1 Specifications

Item	Description
Battery type	3.7 V 18650 standard lithium-ion secondary battery, flat-top, standard 65 mm length
Charge voltage limit	4.2 V
Input voltage/ current	12 V/9 A (instrument's internal power supply) 12 V 3 A (activator)
Output voltage/ current	Max. 11.66 V/9 A Type-C PD 5 V 3 A/9 V 3 A/12 V 3 A/15 V 3 A max
Charging method	CC-CV

Table 8.2 Battery Performance

Item	Description
Nominal voltage	3.7 V
End-of-charge voltage	4.2 V
End-of-discharge voltage	2.5 V to 2.75 V
Charge current allowed	≥ 1.5 A
Discharge current allowed	≥ 5 A
Initial voltage	3.0 V to 4.2 V
Initial voltage variance	± 50 mV (3.6 V to 4.0V) ± 100 mV (3.0 V to 3.6 V/4.0 V to 4.2 V)

Item	Description
Maximum discharge capacity	>1C
Maximum charge capacity	>0.5C
Battery internal resistance	<70 mΩ
Battery capacity	3000 mAh to 3500 mAh
Battery capacity variance	<5% x nominal capacity

Table 8.3 Environmental Specifications

Item	Description	
Ambient temperature	Operating	0 to 40°C
	Storage	Without batteries: -30 to 60°C With batteries: -10 to 50°C
Humidity	Operating	Below +30°C, ≤90% RH (without condensation) +30°C to +40°C, ≤75% RH (without condensation)
	Storage	Without batteries: below 60°C, ≤90% RH (without condensation) With batteries: below 50°C, ≤85% RH (without condensation)
Altitude	Operating	Below 3,000 m
	Storage	Below 15,000 m

Table 8.4 Mechanical Characteristics (Battery Holder)

Item	Description
Dimensions	235.5 mm (W) x 99.2 mm (H) x 61 mm (D)
Weight	Without batteries: 0.874 kg With batteries: 2.020 kg

9 Battery Shipping Label

Handle the self-adhesive label attached to the product package with due attention and care. Before shipping the battery holder package containing batteries, stick the label to the package and fill in your contact information.

UN ID Number: UN3481 (Hazard Class Label: Class 9)



10 Appendix

10.1 Appendix A: Accessories

Item	Qty
Battery Holder	1
Battery Holder Mounting Frame	1
Battery Holder Activator	1
Battery Holder Warranty Card	1
Battery Shipping Label	2

10.2 Appendix B: Warranty

RIGOL TECHNOLOGIES CO., LTD. (hereinafter referred to as RIGOL) warrants that the product mainframe and product accessories will be free from defects in materials and workmanship within the warranty period. If a product proves defective within the warranty period, RIGOL guarantees free replacement or repair for the defective product.

To get repair service, please contact your nearest RIGOL sales or service office.

There is no other warranty, expressed or implied, except such as is expressly set forth herein or other applicable warranty card. There is no implied warranty of merchantability or fitness for a particular purpose. Under no circumstances shall RIGOL be liable for any consequential, indirect, ensuing, or special damages for any breach of warranty in any case.

HEADQUARTER

RIGOL TECHNOLOGIES CO., LTD.
No.8 Keling Road, New District, Suzhou,
JiangSu, P.R.China
Tel: +86-400620002
Email: info@rigol.com

EUROPE

RIGOL TECHNOLOGIES EU GmbH
Carl-Benz-Str.11
82205 Gilching
Germany
Tel: +49(0)8105-27292-0
Email: info-europe@rigol.com

NORTH AMERICA

RIGOL TECHNOLOGIES, USA INC.
10220 SW Nimbus Ave.
Suite K-7
Portland, OR 97223
Tel: +1-877-4-**RIGOL**-1
Fax: +1-877-4-**RIGOL**-1
Email: info@rigol.com

JAPAN

RIGOL JAPAN CO., LTD.
5F,3-45-6,Minamiotsuka,
Toshima-Ku,
Tokyo,170-0005,Japan
Tel: +81-3-6262-8932
Fax: +81-3-6262-8933
Email: info.jp@rigol.com

RIGOL® is the trademark of **RIGOL TECHNOLOGIES CO., LTD.** Product information in this document is subject to update without notice. For the latest information about **RIGOL's** products, applications and services, please contact local **RIGOL** channel partners or access **RIGOL** official website: www.rigol.com